



SB-KEMPII-SB

DESCRIPTION

AMT vaults are designed based on the highest demands of mechanical and environmental resistance, providing an excellent protection performance for underground installations in the electrical, energy and telecommunication sector. Its modular assembly facilitates transportation, storage and installation.

This product is made from recycled polyethylene bags, on strength of the commitment we have of contributing to the ecological balance.

Provides high load capacity, flame retardant protection, resistance to sunlight, abrasive wear, resistance to a variety of chemical agents, in addition to its design, made and tested under international standards.

CHARACTERISTICS



- Manufactured with a modular body of low density polyethylene, fully recycled, while maintaining excellent resistance.
- It is recommended to be used in telecommunications, energy, and electrical substations.
- The cover is secured with galvanized metal hexagonal screws and has handles on the sides for better handling and opening.
- Self-extinguishing material, resistant to solar radiation and abrasion.
- Provides protection against a wide range of chemical agents such as: acids, ketones, solvents, gasses, water vapor, etc.
- Its modular design allows it to be easily transported, stored and assembled.
- Withstands loads of up to 25 tons in compression and tension.
- Optimum to be installed in different environments such as sidewalks, gardens or vehicular streets with intense and heavy traffic.
- Structural design with lateral cavities provides greater support and subterranean anchorage, allowing walls up to 2 inches thick.





Handle for cover lifting.



Customization area with logo.



Hexagonal screws for cover security.



High relief anti-slip surface.



Lateral cavities for better anchoring.



Variety of colors according to requirements.

TECHNICAL SPECIFICATIONS

General register		
Parameter		Value
Distributed load capacity		25 tons
Point load		17 tons
Fatigue strength		1000 cycles with 14.5 Kgf
Flexion		26 mm, 15 Tons
Manufacturing material		Low density polyethylene
Total weight (cover and register)		40.9 Kg
General dimensions	Width	53 cm
	Length	63 cm
	Height	55 cm
Low Density Polyethylene		
Nomenclature (Spanish/English)		PEBD/PELD
Density		0.922 g/cm ³
Breaking strain		20/20 Mpa
Elongation at breaking point DM/DT		380/910 %
Impact resistance		230 g/F50

NORMATIVITY AND STANDARDS



ALT's modular registers are manufactured in full compliance with the following standards, endorsed and certified by the Equipment and Materials Testing Laboratory LAPEM.

Specification	Test load	
	lbf	kN
American		
Pedestrian/Light Duty	3000	14
ANSI/SCTE 77 TIER 15	22500	100
ANSI/SCTE 77 TIER 22	33750	150
APAC		
Pedestrian/Light Duty	3370	15
AS3996-Class B	18000	80
AS3996-Class C	33750	150
EMEA		
Pedestrian/Light Duty	2250	10
EN 124 Class B125	28100	125
EN 124 Class C250	56202	250

PARTS LIST

Part	Quantity	Code
Lower frame	1 piece	MI-KEMP2II-SB
60x55 cm side panels	2 pieces	L60-KEMP2II-SB
50x55 cm side panels	2 pieces	L50-KEMP2II-SB
Top frame	1 piece	MS-KEMP2II-SB
Cover	1 piece	T-KEMP2II-SB
Galvanized hexagonal screws	4 pieces	-
2 1/2" screws	10 pieces	-

DIMENSIONAL SCHEME

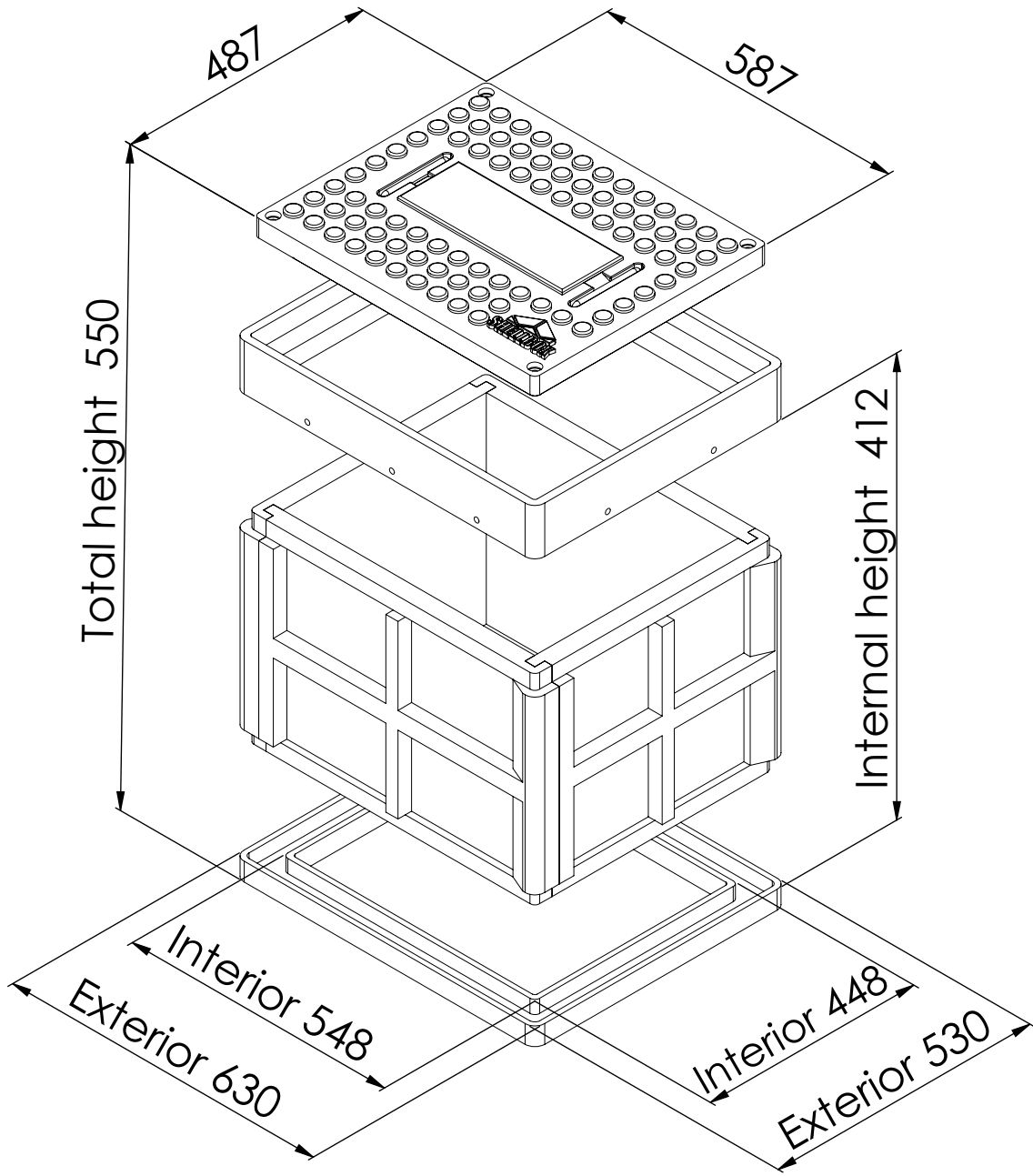

Dimension	Exterior	Interior	Unit
Width	530	448	mm
Length	630	548	mm
Height	550	412	mm

ASSEMBLY STEPS

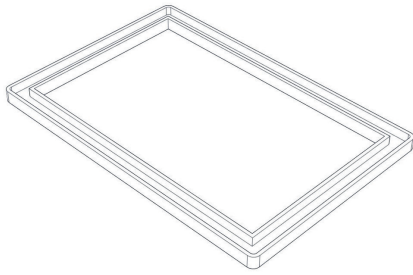

1 Place the lower frame on the floor.

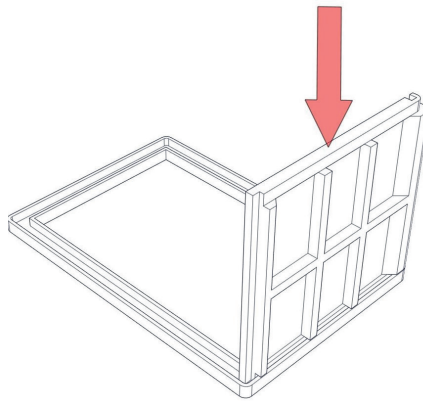

2 Install one of the 60x60 cm square sidewalls on the frame, using a mallet.

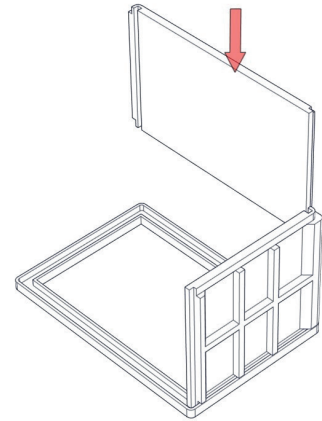

3 Place one of the 60x90 cm rectangular side panels on the other side of the frame, taking into account the coincidence of the male-female assembly of its edges.

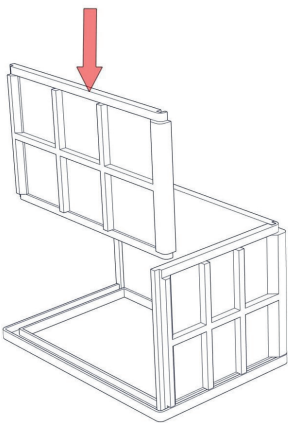

4 Repeat the previous step with the same type of frame, alternating the assembly of the edges.

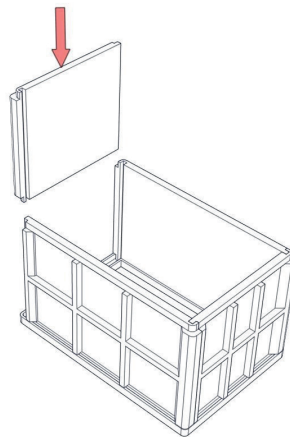

5 Install the last square side in such a way it fits correctly with the rest of the previously installed faces.

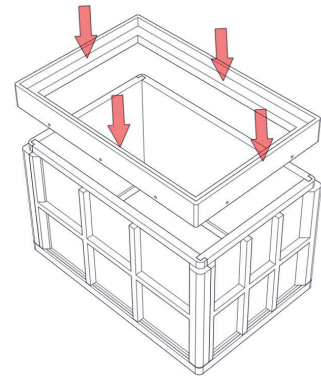

6 Install the top frame.

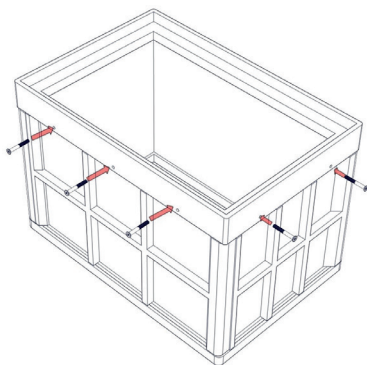

7 Place the 10 screws of 2 1/2" to adjust the top frame to the side faces. The figure shows how to install.

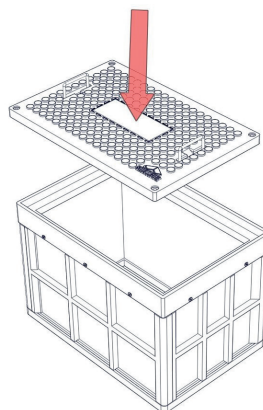

8 Place the cover on the frame using the handles.

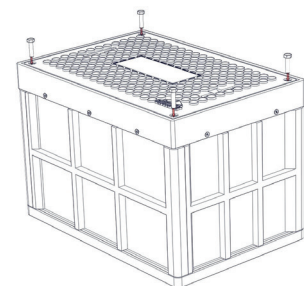

9 Finally install the 4 hexagonal screws in the corners of the cover.

ORDER CONFIGURATION



SB-KEMPPII-SB N/C/HT/HTM

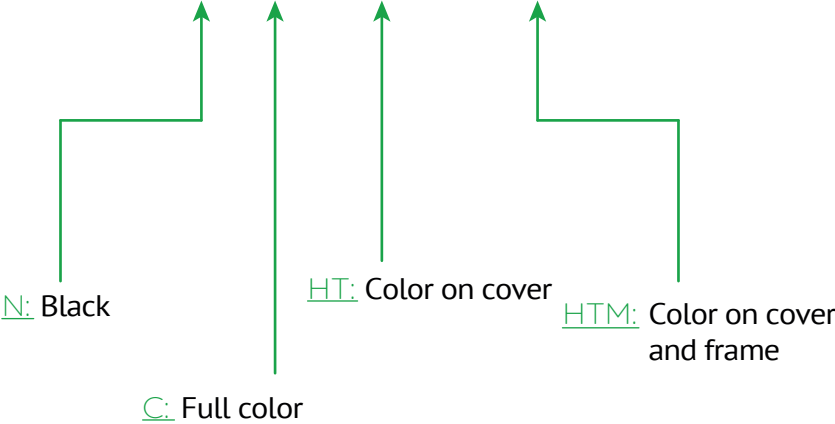

VERSION CONTROL



Ver. No.	Date	Description	Revised by	Approved by
00	21/02/2022	Original emission	Martín S. M.	Alicia Soto