



TMX-4400

100G to 400G Multi-rate DA Series™, Deploy Anywhere, Transponder

The O-Series hardened TMX-4400 transponder, deployed in a TMS-1190 DA Series™ OSP platform, is an ideal, “pay-as-you-grow”, compact DWDM transport solution for 100/200/400G services. It interfaces to standard QSFP28/DD 100G, 200G and 400G client optics, and incorporates a CFP2-DCO DWDM pluggable line interface with software programmable modulation formats that can operate in multiple line mode configurations. Multiple client service configurations can be transported over a single DWDM wavelength with optional physical layer encryption. It provides full client- and line-side performance monitoring for clear service demarcation, fault localization, and SLA assurance.



Features

- Compact Network Application Module (NAM) in TMS-1190 Platform
- Up to 1.6 Tb/s capacity in a single 1RU TMS-1190 shelf
- Hardened 100G to 400G Transport
- Field Replaceable Unit (FRU)
- LLDP

Line Interface

- CFP2-DCO 100/200/400G
- Multiple Modulation Formats
- cFEC, OFEC, SCFEC
- OTU4, OTUCn, openZR+
- Physical and Protocol Performance Monitoring
- AES-256 Encryption

Client Interface

- QSFP28/QSFP-DD
- 100/200/400 GbE, OTU4 and OTUCn
- AOC, SR, FR and LR
- Physical and Protocol Performance Monitoring

Overview

The TMX-4400 provides efficient transponding and DWDM transport for 100/200/400 GbE, and/or OTU client services. The TMX-4400 incorporates a pluggable CFP2-DCO with software programmable modulation formats, and fully-integrated coherent transceiver, including DSP. The line signal can be set to multiple formats to meet industry standards including openZR+, openROADM and Cablelabs® requirements.

It can be used for point-to-point DWDM links of various distances depending on modulation and associated link budget, or provide all-optical transmission over 1000 km or more in amplified fixed grid or gridless systems. Integrated physical layer encryption capabilities are also available.

A single QSFP28 or QSFPDD client interface allows a single 100G/200G/400G client signal to be transponded over a single DWDM wavelength.

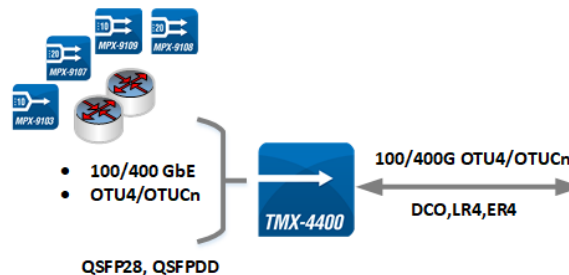

Application

The TMX-4400 is compatible with the ITU flexible grid, and 100 GHz and 50 GHz fixed grids, allowing it to be used with existing DWDM OADM and/or ROADM infrastructure. As a Layer 1 networking device, it transports client services at the full data rate with deterministic low latency. The software programmable line interface allows for a trade-off between reach and spectral efficiency, depending on the OSNR of a given wavelength circuit.

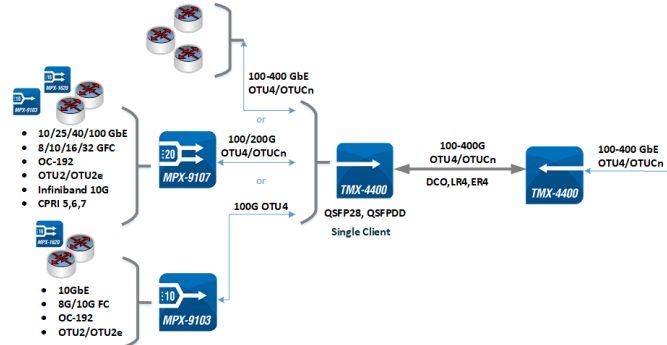

Specifications

| Parameter | Value | Parameter | Value |
|---------------------------------------|--|--|--|
| Card type | Single-slot NAM in TMS-1190 | Line transmit power | 1 dBm (Typical) Integrated VOA (-11 dBm to 1dBm) |
| Line interface | 100/200/400G CFP2-DCO | Line receiver range | -30 to 0 dBm |
| Client interface | 1 QSFPDD 100/200/400GbE, OTU4, OTUCn 1 QSFP28 100GbE, OTUC1, OTU4 | Line receiver sensitivity (dBm) | -23 (400G 16QAM ZR CFEC) -24 (400G 16QAM ZR+ OFEC) -24 (400G 16QAM openROADM OFEC) -30 (100G QPSK SCFEC) * Contact Optelion for full list of receiver sensitivity values |
| Line modulations | 400G 16QAM 200G QPSK 100G QPSK | CD tolerance (ns/nm) | 24 (400G 16QAM ZR CFEC) 26 (400G 16QAM ZR+ OFEC) 26 (400G 16QAM openROADM OFEC) 80 (100G QPSK SCFEC) *Contact Optelion for full list of CD tolerance values |
| Line mappings | OIF 400ZR CFEC, OFEC FlexO OFEC, OTUCn, OTU4 openZR+ *Contact Optelion for full list of line modulation and mapping combinations | Operating temperature (outside plant) | -40°C to 65°C (-40°F to 149°F) |
| OSNR sensitivity, typical (dB) | 22.8 (400G 16QAM ZR CFEC) 21.1 (400G 16QAM ZR+ OFEC) 21.6 (400G 16QAM openROADM OFEC) 12.8 (100G QPSK SCFEC) *Contact Optelion for full list OSNR sensitivity values | Storage temperature | -40°C to 85°C (-40°F to 185°F) |
| FEC | CFEC, OFEC, SCFEC | Compliance | GR-63-CORE, GR-3108-OSP Class 2 |

Ordering Information

| Model Number | Part Number | Description |
|--------------|-------------|--------------------------------------|
| TMX-4400 | 1032-2001 | TMX-4400 400G Multi-rate Transponder |

Distribution partner

