

Product Overview

Motorola's 1 GHz STARLINE® BLE100 Broadband Line Extender leads the industry in features and performance. This two-way-capable single-output amplifier offers high gain, high output levels, ergonomics, superior distortion performance, multiple diplex filter options, 16 dB return loss, and Bode equalization, as well as optional advanced features such as ingress control switching and status monitoring.

Enhanced Gallium Nitride

Motorola's STARLINE BLE100 1 GHz Amplifiers now feature Gallium Nitride (GaN) Output Hybrids to allow for an increased drive level while maintaining existing specifications. The GaN hybrid technology allows for 3 dB of increased drive level over the existing Gallium Arsenide (GaAs) technology. The GaN technology also provides for increased reliability that raises the Electro Static Discharge (ESD) levels by 3kV—putting them at the reliability level of Silicon (Si) technology.

High Gain

The BLE100 offers high gain, allowing the operator to hold existing amplifier locations during system upgrades, reducing maintenance, installation, and powering costs.

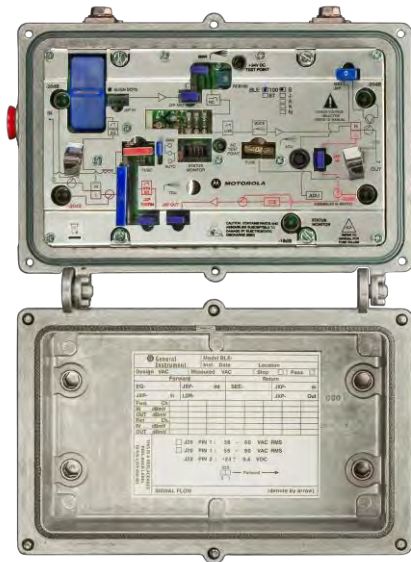

Return Path

High-gain return amplifiers providing 24 dB minimum station gain are available. Return path equalizers from 0 to 12 dB can be selected. Thermal compensation is an optional feature, available as a plug-in JXP-TH*C, which stabilizes gain and match over temperature extremes.

Ingress Control Switching (ICS) in three states is also available. This pin diode attenuator circuit can lower levels by 6 dB or by 38 dB with a controlled slew rate for minimum bit errors. The LIFELINE® Broadband Line Extender transponder (available directly from Opterna AM) and accompanying deeper housing lid are required to operate the Ingress Control Switch from a remote location.

Features

- 1002 MHz Enhanced Gallium Nitride (E-GaN) power doubling technology
- High gain
- High output level
- Multiple diplex filter frequency split options
- N-split (5 to 85 MHz/104 to 1002 MHz) available
- Ease-of-use ergonomics
- 16 dB return loss
- 60/90 V powering
- Meets Telcordia GR-1098-Core voltage surge requirements using IEEE C62.41 surge waveforms
- FCC, CENELEC, and CCC approved
- RoHS-compliant models available
- Bode equalization (thermal or auto controlled)
- 15 A AC capability
- Optional return path ingress control and status monitor
- Directional coupler—20 dB test points

Forward Path

The operational gain of the BLE100 is 34 dB, with 16 dB return loss. Output level control is achieved through the use of an interstage Bode equalizer, which compensates for coaxial cable attenuation changes due to temperature. Equalization may be controlled manually, with a thermal drive unit (TDU), or with a single-pilot closed-loop automatic drive unit, model ADU-* (analog pilot) or QADU-* (QAM pilot). Both the ADU and QADU boards are common to the STARLINE family of amplifiers (with the exception of the SLE and MBV3). ADUs use Surface Acoustic Wave (SAW) filters for determining pilot frequency, improving amplifier stability over temperature.

To further ensure system flexibility, installation ease, and maintenance, the amplifier is engineered for compatibility with standard accessories, such as attenuators, equalizers, ADUs or QADUs, return amplifiers, automotive fuses, and FTEC crowbar circuits.

The BLE100 uses modular duplex filters, which can be changed for a different frequency split as required.

The following filters are available for use with all US-style Motorola RF distribution amplifiers (models BLE, MB/MBV3, BT):

- K-split (5 to 42 MHz/54 to 1002 MHz)
- A-split (5 to 65 MHz/85 to 1002 MHz)
- N-split (5 to 85 MHz/104 to 1002 MHz)

Backward Compatibility

The BLE100 electronics package can be made backward compatible with the BLE-15A Kit. These kits contain 50 mil gold plated platform assemblies. This makes it possible for the amplifier to carry 15 Amperes continuous through the input or output ports.

Block Diagram

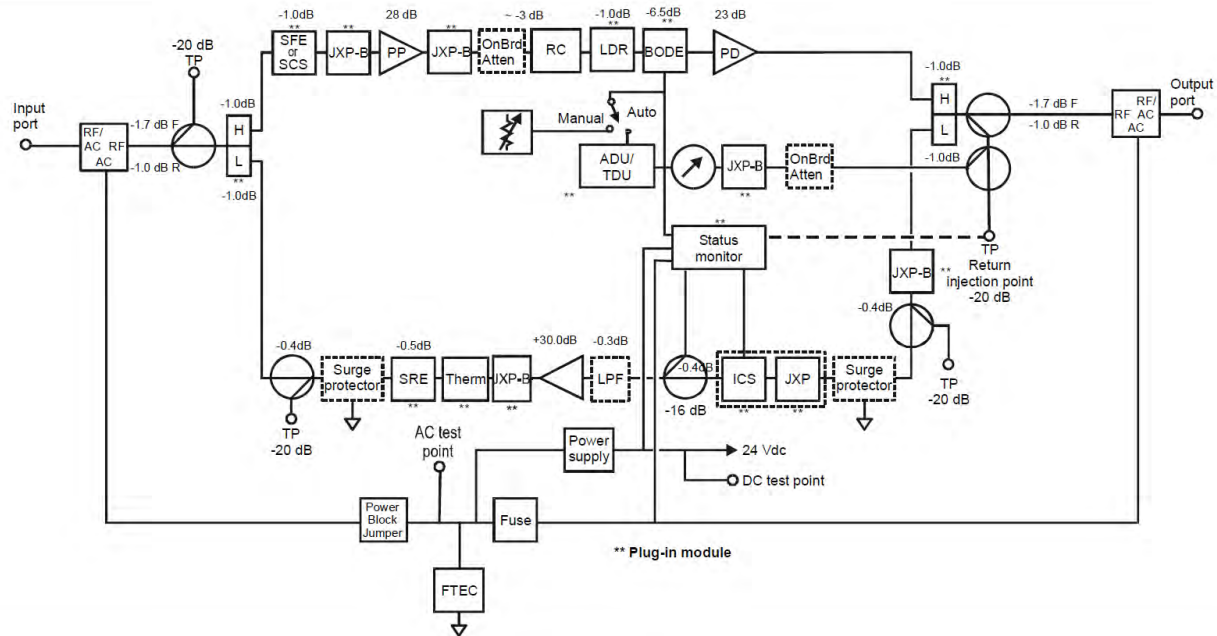

Specifications

BLE100K GaN series

Specifications	Units	Notes:	Forward		Return
Frequency split (K)	MHz	1	54-1002		5 – 42
Flatness	dB	2	+/- 0.7		+/- 0.5
Minimum Full Gain	dB	3	37		
Operation Gain	dB	4	34		20
Manual Bode Slope Control Range	dB	5	+3 / -5		
Operating Tilt (linear)	dB		14	18	
Interstage Equalizer Slope	dB	6	9 +/- 1	13 +/- 1	
Noise figure	dB	7	8	10	5.5
Reference Frequency	MHz	8	1002/550/54		5 -42
Reference Output Level 79 analog chs / 450 MHz QAM	dBmV	8	51/44/37	57/48/39	35 (flat)
Distortion	dBc	21			
CCN79	dB		60	60	
CTB79	dBc	9,19	77	73	80
XM79	dB	10,19	70.5	62	70
CSO79	dBc	9,11,19	71	70	81
Reference Frequency	MHz	8	1002/54	1002/54	
Reference Output Level 948 MHz QAM	dBmV	8	51/37	57/39	40(Flat)
NPR	dB	19	51	50	>60
MER	dB	19	42.5	42	>42
Test Point	dB	12	20 (+/- 1.0 dB)		
Return Loss	dB	13	16		15
Hum Modulation @ 15A	dBc	14	<65dB		
DC Voltage	VDC	15	24		
DC Ripple	mV		16 p-p		
AC Input Voltage Range	VAC		38-90		
Current DC	mA	16	925	995	
Power Consumption	W		26.6	28.8	
AC Current Draw	A		2-way	with ADU	
@ 90 VAC			0.56	0.6	
@ 75 VAC			0.59	0.64	
@ 60 VAC		17	0.65	0.71	
@ 53 VAC			0.7	0.77	
@ 45 VAC			0.78	0.85	
@ 38 VAC			0.88	0.95	
AC Bypass Current (all ports)	A	17	15A		
Group Delay, 55.25 to 58.83 MHz	nSec	18	32		
Operating temperature range	°C		-40 to +60		
Housing dimensions, W x H x D	Inches		10.6 L x 8.0 W x 4.7 D		
Weight	lb		7.2		

BLE100N GaN series

Specifications	Units	Notes:	Forward		Return
Frequency split (N)	MHz	1	104-1002		5 – 85
Flatness	dB	2	+/- 0.7		+/- 0.5
Minimum Full Gain	dB	3	37		
Operation Gain	dB	4	34		20
Manual Bode Slope Control Range	dB	5	+3 / -5		
Operating Tilt (linear)	dB		13	17	
Interstage Equalizer Slope	dB	6	9 +/- 1	11 +/-1	
Noise figure	dB	7	8	10	5.5
Reference Frequency	MHz	8	1002/550/104		5 – 85
Reference Output Level 74 analog chs / 450 MHz QAM	dBmV	8	51/44/38	57/48/40	35 (flat)
Distortion	dBc	21			
CCN	dB		61	60	
CTB	dBc	9,19	77	74	80
XM	dB	10,19	70.5	62	70
CSO	dBc	9,11,19	72	70	81
Reference Frequency	MHz	8	1002/104		
Reference Output Level 898 MHz QAM (virtual analog levels)	dBmV	8	51/38	57/40	40 (Flat)
NPR	dB	19	51	50	>60
MER	dB	19	42.5	42	>42
Test Point	dB	12	20 (+/- 1.0 dB)		
Return Loss	dB	13	16		15
Hum Modulation @ 15A	dBc	14	<65dB		
DC Voltage	VDC	15	24		
DC Ripple	mV		16 p-p		
AC Input Voltage Range	VAC		38-90		
Current DC	mA	16	925	995	
Power Consumption	W		26.6	28.8	
AC Current Draw	A	17	2-way	with ADU	
@ 90 VAC			0.56	0.6	
@ 75 VAC			0.59	0.64	
@ 60 VAC			0.65	0.71	
@ 53 VAC			0.7	0.77	
@ 45 VAC			0.78	0.85	
@ 38 VAC			0.88	0.95	
AC Bypass Current (all ports)	A	17	15A		
Group Delay, 109.25 to 112.83 MHz	nSec	18	14		
Group Delay, 112.25 to 116.68 MHz	nSec	18	12		
Operating temperature range	°C		-40 to +60		
Housing dimensions, W x H x D	Inches		10.6 L x 8.0 W x 4.7 D		
Weight	lb		7.2		

DATA SHEET STARLINE® SERIES BLE100 1 GHZ LINE EXTENDER

*Specifications are subject to change without notice.

*All specifications are stated as worst-case over temperature unless otherwise noted.

1. Operating passband of station.
2. Referenced to the average gain across the passband.
3. Minimum full gain at 1002 MHz includes loss of equalizer but Bode slope reserves have not been set. Return gain includes loss of SRE-4 return equalizer.
4. Includes loss of slope reserves as well as equalizer.
5. From midpoint (typical setting is -3 dB at 1002 MHz @ 20 °C). This control should not be used for gain reduction.
6. Amount of slope created and cable equivalence of fixed, plug-in interstage equalizer.
7. Specified at the housing cable entry facility and includes the loss of 1 dB for the pre-stage equalizer. The return noise figure includes the station loss preceding the RF hybrid.
8. Frequencies that relate the picture carriers or QAM channels to the specified output levels and tilts. QAM channels are virtual (-6 dB down from analog picture carrier).
9. Measured with CW carriers and spectrum analyzer over specified temperature range. References are typical across the band of interest. *
10. Measured with wave analyzer and synchronous, 100% depth modulated channels. References are typical across the band of interest. *
11. Refers only to beat clusters that fall 0.75 MHz and 1.25 MHz above the subject picture carrier.
12. Test points should be used with GFAL adapter.
13. Match measurement at the station input and output, cable-entry facilities, at the specified passbands for operational gain.
14. Measured with the AC bypass current.
15. Measured at the power connector.
16. Current draw at 24 VDC.
17. Stated in RMS continuous.
18. Specified for standard NTSC video, where delay is the delta from picture carrier to 3.58 MHz color subcarrier. Reverse delay is in a 1.5 MHz bandwidth.
19. Typical performance over the stated temperature range in a cascade.
20. NTSC 79 Channel forward and 6 channel return, QAM carriers, -6 dB relative to the analog CW carriers.
21. Stated specification and performances are referenced with the use of Motorola accessories. The noted parameters will not be supported when third party accessories are employed.
22. NPR - Noise Power ratio , is measured at the center frequency of the band of interest with a full noise load
23. MER – Modulation Error Ratio – is measured with a BER/MER analyzer and a source using an J.83, Annex datastream.

*Specifications are compliant with the test methods as stated in NCTA Recommended Practices for Measurements on Cable

DATA SHEET STARLINE®SERIES BLE100 1 GHZ LINE EXTENDER

Ordering Information

Part Number	Model Name	Description
811000-015-00	BLE100K-GXXH-F-R	STARLINE ergonomic 1 GHz BLE with 5–42/54–1002 MHz K-split, manual gain control
811000-016-00	BLE100K-GXXH-E15-R	STARLINE ergonomic 1 GHz BLE with 5–42/54–1002 MHz K-split, manual gain control, 15 A electronics module only (no housing)
811000-018-00	BLE100K-GAXH-F-R	STARLINE ergonomic 1 GHz BLE with 5–42/54–1002 MHz K-split, QAM 499.25 MHz gain control
811000-017-00	BLE100K-GQXH-F-R	STARLINE ergonomic 1 GHz BLE with 5–42/54–1002 MHz K-split, QAM ADU 609.00 MHz gain control
811000-020-00	BLE100K-GSXH-F-R	STARLINE ergonomic 1 GHz BLE with 5–42/54–1002 MHz K-split, QAM ADU 711.00 MHz gain control
811000-011-00	BLE100K-GXUH-F-R	STARLINE ergonomic 1 GHz BLE with 5–42/54–1002 MHz K-split, Ultra Slope
811000-025-00	BLE100K-GXUH-E15-R	STARLINE ergonomic 1 GHz BLE with 5–42/54–1002 MHz K-split, Ultra Slope, 15 A electronics module only (no housing)
811000-014-00	BLE100N-GXXH-F-R	STARLINE ergonomic 1 GHz BLE with 5–85/104–1002 MHz N-split
811000-023-00	BLE100N-GXXH-E15-R	STARLINE ergonomic 1 GHz BLE with 5–85/104–1002 MHz N-split, 15 A electronics modules only (no housing)
811000-022-00	BLE100N-GQXH-F-R	STARLINE ergonomic 1 GHz BLE with 5–85/104–1002 MHz N-split, QAM ADU 609.00 MHz gain control
811000-021-00	BLE100N-GQXH-E15-R	STARLINE ergonomic 1 GHz BLE with 5–85/104–1002 MHz N-split, QAM ADU 609.00 MHz gain control, 15 A electronics module
811000-008-00	BLE100N-GXUH-F-R	STARLINE ergonomic 1 GHz BLE with 5–85/104–1002 MHz N-split, Ultra Slope
811000-013-00	BLE100A-GXXH-F-R	STARLINE ergonomic 1 GHz BLE with 5–65/85–1002 MHz A-split, Ultra Slope
811000-012-00	BLE100A-GXXH-E15-R	STARLINE ergonomic 1 GHz BLE with 5–65/85–1002 MHz A-split, Ultra Slope, 15 A electronics module only (no housing)
811000-009-00	BLE100A-GXUH-F-R	STARLINE ergonomic 1 GHz BLE with 5–65/85–1002 MHz A-split, Ultra Slope
Required Accessories		
535723-001-00	SFE-100-0	One of the following per BLE: STARLINE forward 1002 MHz equalizer (0 dB) -or-
531124-001 to -022	SFE-100-1 to -22	STARLINE forward 1002 MHz equalizer (values 1 to 22 dB in 1 dB steps) -or-
531161-001 to -010	SCS-1 to SCS-10	STARLINE cable simulator (values 1 to 10 dB in 1 dB steps)
531163-XXX-00	SRE-*.*	STARLINE return equalizer,5-40 MHz (S-split),5-42 (K-split),5-55 (J-split),5-65 (A-split),values 0 to 12 dB in 1 dB steps for S-split (2 dB steps for all other frequency splits) (one per BLE)
531186-XXX-00	JXP-*.B	Plug-in attenuator/pad (values 0 to 26 dB in 1 dB steps (up to five per BLE)

1 GHz BLE Ordering Guide

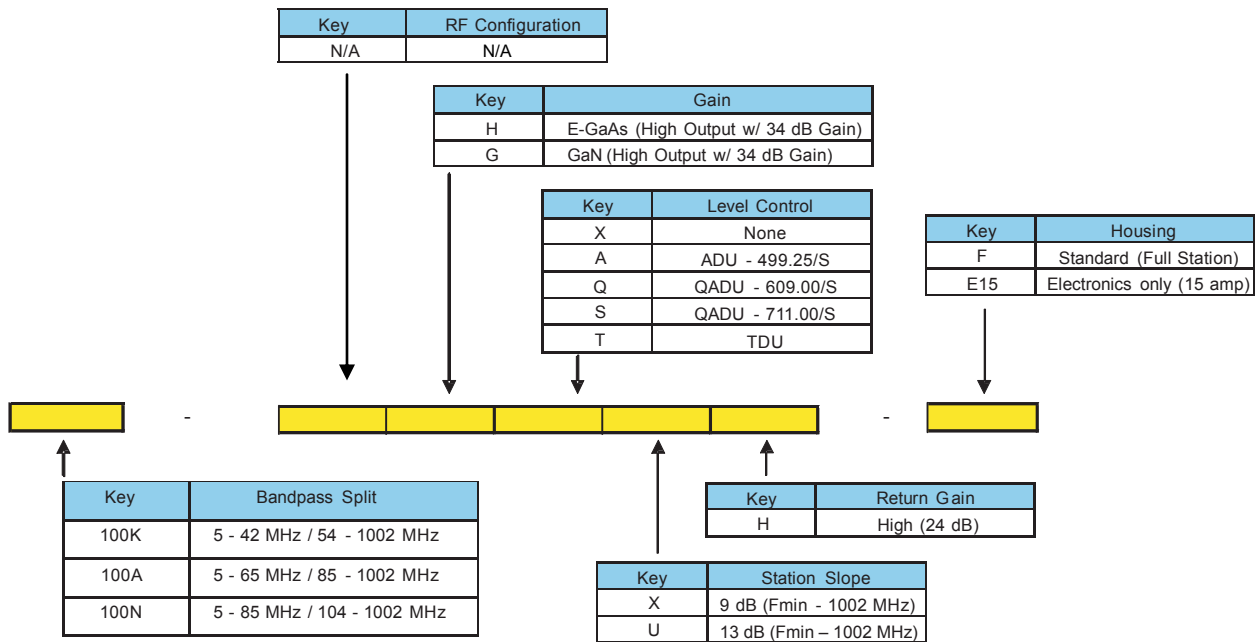

Notes:

- 1) Not all combinations in the ordering guide are available. This is a guide only. Please see "Ordering Information" in data (page 4) or Customer Print Sheet in pricing tool for a complete list of available models.
- 2) FTECs are included in all models as standard, except for the "vanilla" models, BLE-100*H, which contain the standard gas tube surge arrestor
- 3) 20A fuses are included in all amplifiers as standard
- 4) ICS and status monitor transponders will continue to be customer configurable options.
- 5) For RoHS models, add "-R" to the end of the model string.



MOTOROLA and the Stylized M Logo are trademarks or registered trademarks of Motorola Trademark Holdings, LLC. All other product or service names are the property of their respective owners. ©2012 Motorola Mobility, Inc. All rights reserved.

365-095-14729 x.4 08/12 UNCONTROLLED DOCUMENT - FOR REVIEW ONLY